



## P.A. - S.r.l. - EQUIPAGGIAMENTI TECNICI DEL LAVAGGIO

VIA MILANO, 13 - 42048 RUBIERA (REGGIO EMILIA) - ITALY - Tel. +39 0522 623611 (10 linee)  
 Fax +39 0522 629600 - R.E.A. RE 156319 - Registro Imprese RE 11535 - Mecc. RE 013446  
 C.F. e P.IVA 01035950359 - Cap. Soc. i.v. € 750.000,00 - Codice Identificativo C.E.E. IT 01035950359  
 ART. 2497 - BIS C.C. DIREZIONE E COORDINAMENTO BENETTI srl R.I. TRIB. DI RE 01480690351  
<http://www.pa-etl.it> - E-mail: [info@pa-etl.it](mailto:info@pa-etl.it)



## PULSAR 3 - Unloader Valve (discharging)

Technical manual: **E 211**

Pressure regulating unloader valve, equipped with double connection for both inlet and discharge.  
 Possibility of different pressure settings by a choice of 2 spring models. At gun shut off, the water flow is bypassed at reduced pressure.

DN 10



- **60.0000.00** Pulsar 3 white spring
- **60.0000.60** Pulsar 3 blue spring
- **60.0006.00** Pulsar 3 white spring w/cap
- **60.0006.60** Pulsar 3 blue spring w/cap
- **60.0000.05** Pulsar 3 white spring Npt
- **60.0000.65** Pulsar 3 blue spring Npt
- **60.0006.05** Pulsar 3 white spring w/cap Npt
- **60.0006.65** Pulsar 3 blue spring w/cap Npt

- Sturdy steel and brass construction
- Returning action of the piston by means of powerful springs, for positive working and a reliable pressure adjustment.
- Multiple connections for easy installation.
- Hexagonal shaped check valve to avoid jamming.
- Possibility to fit a venturi injector, on delivery, for chemicals.
- Version with knob, fitted with locknut for min. and max. pressure regulation.

### Technical Specifications

Max. flow rate: 30 l/min. (1) Max temperature: 90°C (2)

Part Number	Rated pressure	Permissible pressure	Minimum adjustable pressure	(3)Trapped pressure at circuit closure	(4)Pressure drop to reset bypass	Inlet Outlet bypass	Weight g
	bar - MPa	bar - MPa	bar - MPa	%	%		
60.0000.00	100 -10	120 - 12	10 - 1	17%	26%	G3/8F	700
60.0000.60	220 - 22	250 - 25	22 - 2.2	12%	31%	G3/8F	735
60.0006.00	100 - 10	120 - 12	10 - 1	17%	26%	G3/8F	750
60.0006.60	220 - 22	250 - 25	22 - 2.2	12%	31%	G3/8F	780
60.0000.05	100 -10	120 - 12	10 - 1	17%	26%	Npt F	700
60.0000.65	220 - 22	250 - 25	22 - 2.2	12%	31%	Npt F	735
60.0006.05	100 - 10	120 - 12	10 - 1	17%	26%	Npt F	750
60.0006.65	220 - 22	250 - 25	22 - 2.2	12%	31%	Npt F	780

(1) Max. flow rate: 15l/min if fed through the lower connection.

(2) The valve has been designed for a continuous use at a water temperature of 60°C. It can resist for short periods at a maximum temperature of 90°C.

(3) This is the maximum pressure increase implemented in the circuit for the intervention of the valve and to bring all the fluid in bypass (percentage figures of the pressure set up)

(4) This is the pressure reduction necessary in comparison to the set up, in order that the valve brings back pressure in the circuit. (percentage figures of the pressure set up)

**Instruction manual, maintenance, installation, spare parts.**

For a correct utilization, follow the directions of this manual

**Re-print them on the Use and Maintenance booklet of the machine.**

n. 12.9211.00

## DIMENSIONAL DRAWING

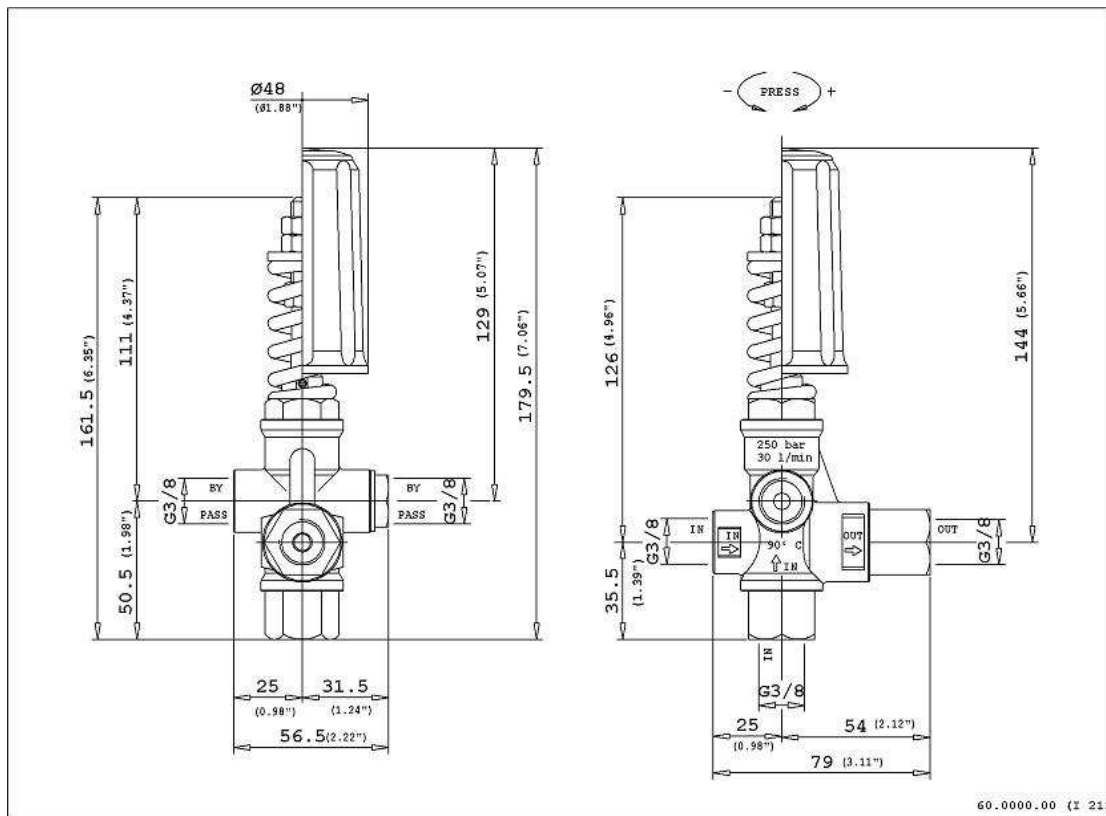

## INSTRUCTIONS

### SELECTION

This product is to be utilized with clean fresh water, even slightly additivated with normal detergents. For use involving different or corrosive liquids, contact the PA Technical department. Appropriate filtration should be installed when using unclean liquids. Choose the valve in line with the data of nominal running (system rated pressure, max flow and max temperature). In any case, the pressure of the machine should not exceed the permissible pressure rate imprinted on the valve. The supply of the lower connection is possible with reduced flow rate (**see point 1**)

### INSTALLATION

This accessory, on a system that produces hot water, must be fitted in **front of the heat generator**. This product is bound to be incorporated on a finished machine. On a system that generates hot water, anticipate the fitting of accessories that limit the accidental increase of fluid temperature.

**Always install a safety valve that protects the pressurized inlet channel.**

Choose a correct nozzle size, which allows a regular discharge on bypass, at least 5% of the total flow of the system in order to achieve a constant pressure value and avoid troublesome pressure spikes at closure. If the nozzle wears out, the pressure drops.

On installation of a new nozzle, re-adjust the system to the original pressure setting. The utilization of the white spring (100bar – 10MPa) is advised for comparatively low pressures in order to reduce motor strain caused by overpressures, which are necessary to switch over to the bypass mode.

### OPERATIONS

The valve regulates the max pressure of the system through a piston, which acts on a ball correctly positioned, that closes the bypass opening. A check valve cuts out the delivery section, the pressure of which controls the drive of the piston.

Each regulation should be made when the system is operational and the nozzle open.

In the version WITHOUT KNOB; after regulating the valve to the fixed pressure, lock the two nuts (pos.16) and brush stroke them with paint to avoid any tampering.

In the version WITH KNOB; lock the nut (pos.14) to fix the max pressure and set the locknut (pos.33) to define the min pressure.

**ATTENTION: The nuts (pos.14 #1 pc) and (pos.16 #2 pcs) must never be removed otherwise a mechanical safety feature that limits the max pressure will lack, avoiding serious damage to persons and machine.**

### DISCHARGE SYSTEM AND WATER ADDUCTION

The bypass line should be returned into a tank with deflectors. By using a direct pump recycle, with elevated pressure intake, it is necessary to install a pressure reducer in order to have an even flow supply and to protect the circuit intake.

When the system is opened and closed frequently, it is recommended to install a thermal protector valve (VT3 or VT6) in order to eliminate excessive temperature build-up. It is advisable to fit, for the bypass line direct to the pump, an appropriate sized hose of at least 250mm length.

## PROBLEMS AND SOLUTIONS

PROBLEMS	PROBABLE CAUSES	SOLUTIONS
Frequent unloader recycles	Damaged check valve O ring Leaking connections Restricted bypass	Replace Check and renew Clean or adapt
Unloader does not reach pressure	Unloader not properly sized Piston O rings worn out Material matter between seat and shutter Worn out nozzle	Change spring or type of valve Replace Clean the seat Replace
Pressure peaks	There is not a min of 5% of total flow in bypass Excessive flow in bypass Spring totally compressed	Reset Change type of valve or adjust passages Loosen knob and change nozzle
Unloader does not bypass at low pressure	Jammed check valve Check valve O ring worn out Material matter on check valve	Clean or replace Replace Clean

**REGULATIONS :** *see norm manual*

**The accessory hereby described bears the CE marking in accordance with the Norms and Directives applied on the Declaration of conformity.**

For a correct utilization, follow the directions described in this manual and re-print them on the Use and maintenance manual of the machine.

Make sure that you are given **the Original Conformity Declaration** for the accessory chosen. The present manual is valid for all unloader valves named **Pulsar 3**.

## **MAINTENANCE**

Maintenance has to be carried out by **Specialized Technicians**.

**STANDARD:** every 400 working hours (circa 10,000 cycles), check and lubricate the seals with water resistant grease.

**SPECIAL:** every 800 working hours (circa 20,000 cycles), control the wear of the seals and internal parts and if necessary, replace with original PA parts taking care during installation and to lubricate with water resistant grease.

**ATTENTION:** reassemble the valve in the correct manner paying special attention to the Nuts (pos 14) by fastening them with a drop of a strong glue.

**The manufacturer is not to be considered responsible for damage as a result from incorrect fitting and maintenance**

Technical data, descriptions and illustrations are indicative and liable to modification without notice.

60.0000.00 Pulsar 3 unload. 3/8F Bsp-120bar  
 60.0000.60 Pulsar 3 unload. 3/8F Bsp-250bar  
 60.0006.00 Pulsar 3 unload. 3/8F Bsp-120bar+knob  
 60.0006.60 Pulsar 3 unload. 3/8F Bsp-250bar+knob

60.0006.62 Pulsar3 unload.3/8F Bsp-250bar+kn.+p.ftg  
 60.0006.65 Pulsar 3 unload. 3/8F Npt-250bar+knob  
 60.0073.21 Pulsar3 250 Unl.+fix.inj.3/8Bsp M 2,1mm  
 60.0076.60 Pulsar 3 unld.3/8F Bsp+1/4 prt-250bar+kn

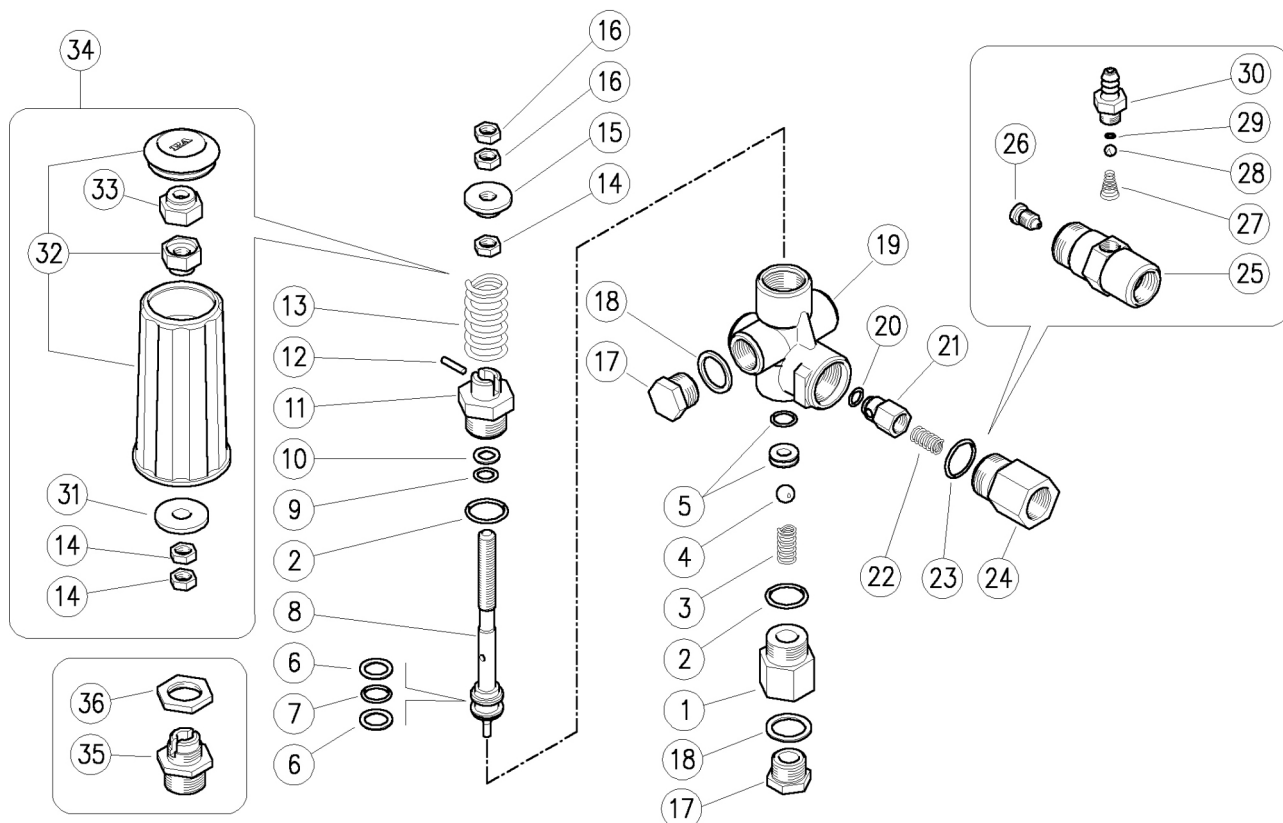

Pos.	P/N	Description	Q.ty	K1	K2	K3	K4	Kit	Pos.	P/N	Description	Q.ty	K1	K2	K3	K4	Kit
1	60.0024.31	Suction coupl., 3/8F Bsp brass	1					10	19	60.0051.35	Housing -Pulsar3, 3/8Bsp FFF brass	1					1
1	60.0030.31	Suction coupl., 3/8F Npt brass (1)	1					10	19	60.0057.35	Housing -Pulsar3, 3/8Npt FFF brass (1)	1					1
2	10.3068.00	O-ring, 1,78x17,17 mm	2	.	.			10	19	60.0045.35	Housing -Pulsar3, 3/8F+1/4F Bsp brass (5)	1					3
3	60.0015.51	Spring, 1,4x10x16 mm Sst.	1					10	20	10.3213.00	O-ring, 3x6 mm	1	.	.			10
4	14.7443.10	Ball, 11/32" Sst.	1	.	.			10	21	60.0052.31	Shutter pin, brass	1					10
5	30.0031.201	Spares kit -Seat, 7mm+O-ring 25pcs.	1	.	.			1	22	60.0053.51	Spring, 0,7x9x20 mm Sst.	1					10
6	10.4021.00	Back-up ring, opn. 11,5x15,9x1,2 mm	2	.	.			10	23	10.3070.02	O-ring, 1,78x18,77 mm Ni 85	1	.	.			10
7	10.3175.00	O-ring, 2,62x10,77 mm	1	.	.			10	24	60.0058.31	Delivery coupl., 3/8F Bsp brass	1					5
8	60.0061.23	Valve piston, Sst.	1					5	24	60.0059.31	Delivery coupl., 3/8F Npt brass (1)	1					5
9	10.3170.00	O-ring, 2,62x7,6 mm	1	.	.			10	25	21.0261.31	Inject.hous.,M22x1,5M-3/8M Bsp brass (6)	1					3
10	10.4020.00	Back-up ring, 8x12,6x1,2 mm	1	.	.			10	26	21.0213.51	Nozzle, M8x1 - 2,1 mm Sst.	1					10
11	60.0064.31	Piston holder, brass	1					5	27	21.0160.51	Tapered spring, Sst. -inject.	1					10
12	15.1021.00	Roll pin, 3x14 mm Sst.	1					10	28	14.7420.01	Ball, 7/32" Sst. Aisi 316	1					10
13	60.0012.61	Spring, 5x25x50 mm white (2)	1					5	29	10.3049.00	O-ring, 1,78x5,28 mm Vi 70	1					10
13	60.0033.61	Spring, 5,7x26x53 mm blue (3)	1					5	30	21.0003.31	Hose barb, 8 - M12x1 mm brass	1					10
14	11.4573.31	Hex. nut, M8, brass (2)	1					10	31	14.3720.40	Washer, 9,2x24x0,5 mm (4)	1					10
14	11.4573.31	Hex. nut, M8, brass (4)	2					10	32	60.0004.24	Knob + Plug -Pulsar3 (4)	1					5
15	60.0011.31	Spring holder ring, brass (3)	1					5	33	11.4589.10	Hex. locknut, M8	1					10
16	11.4574.00	Hex. nut, M8	2					10	34	60.0014.24	Knob Kit -Pulsar3, 6x1pcs. (4)	1					1
17	60.0028.31	Plug,brass 3/8 Bsp,hex.19	2					25	35	60.0185.31	Piston hold.+panel fitting, 3/8M Bsp brs (7)	1					3
17	60.0025.31	Grub screw, brass 3/8M Npt (1)	2					10	36	29.0171.31	Nut, brass, 3/8F Bsp (7)	1					50
18	14.4042.00	Washer, 16,7x22x1,5 mm alu.	2					25									

Kit	P/N	Description	Kit
K1	60.0005.24	Spares kit -Pulsar3, 10x5pcs.	1
K2	60.0056.24	Spares kit -Pulsar3, 10x1pcs.	1

(1) 60.0006.65 (2) 60.0000.00 (3) 60.0000.60 (4) 60.0006.00 (5) 60.0076.60 (6) 60.0073.21 (7) 60.0006.62