

Floor Mount

- ✓ for 1 to 2 booms
 - ✓ up to 180° or 360° rotation
 - ✓ polished stainless steel
 - ✓ tough design
 - ✓ ready to use
- MOSMATIC Dry**
- ✓ dryer for Air-boom
 - ✓ ready to use



LU-B (Floor Mount 360°)

Part No.	ø	Weight
60.303	40	17.1kg
60.312	50	21.8kg

incl. Air-boom

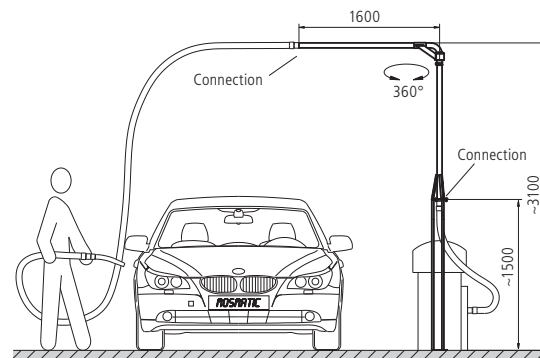

LU-Z (Air-boom-Post)

Part No.	Weight
60.318	24.0kg

without Air-boom

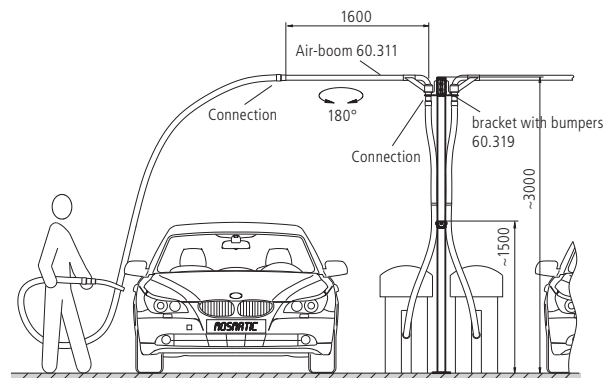

MOSMATIC DRY

Dryer unit suitable for all MOSMATIC Air-booms. A new attraction in your wash bay.

Part No.	Weight
60.396	32.0kg

Accessories see page 72



Universal dryer used for cars, motorcycles and boats. For wall or ceiling installations. Also installs directly to vacuum cleaner universal mounting plate.

- Ready to use:
- dryer, 230V, illuminated
 - 2x 1600 watt motors
 - air-gun
 - gun-holder
 - hoses for connections
 - operator's guide board
 - assembly instructions

Legend

M. = metric thrust, **..M** = male, **F** = female, **G** = gas pipe thrust, **QV** = quick connects, **SV** = profile ring fitting
D = diameter, **k** = conical, **L** = length, **NW** = nominal width, **SW** = wrench size, **IN** = media input, **OUT** = media output, **RS** = basic position